

Transmission

Removal

1. With the vehicle in NEUTRAL, position it on a hoist. For additional information, refer to [Section 100-02](#).
2. Disconnect the battery ground cable. For additional information, refer to [Section 414-01](#).
3. Remove the gearshift lever knob and boot.
 - Turn the gearshift lever knob in a counterclockwise direction.

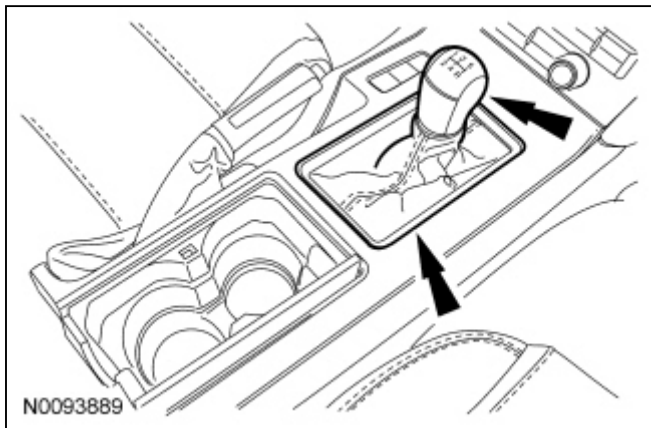

4. Remove the catalytic converter H-pipe. For additional information, refer to [Section 309-00](#).
5. **NOTE:** Index-mark the driveshaft flange and pinion flange, and the driveshaft flange and output shaft flange.

Remove the driveshaft. For additional information, refer to [Section 205-01](#).

6. Remove the 3 starter motor bolts and position the starter motor aside.

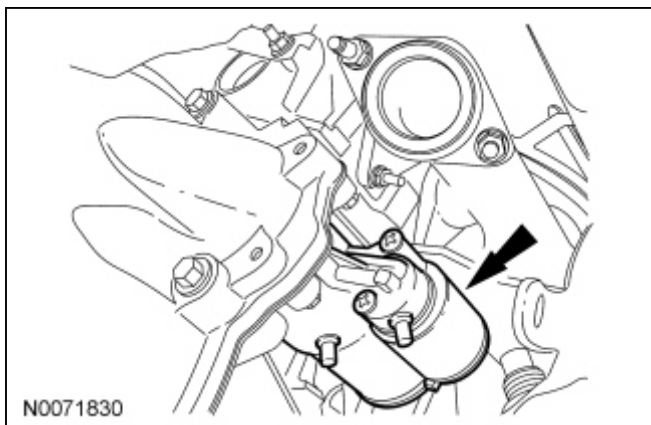

7. Remove the 4 subframe cross brace nuts and the subframe cross brace.

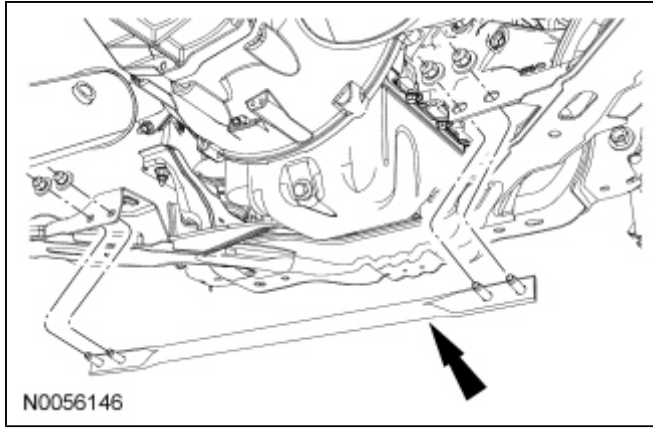

8. Disconnect the reverse lamp switch electrical connector. Disconnect the wiring harness from the transmission.

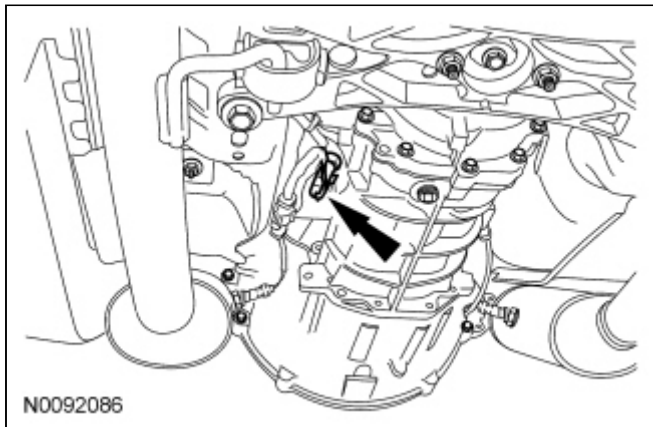

9. Disconnect the Output Shaft Speed (OSS) sensor electrical connector. Disconnect the wiring harness from the transmission.

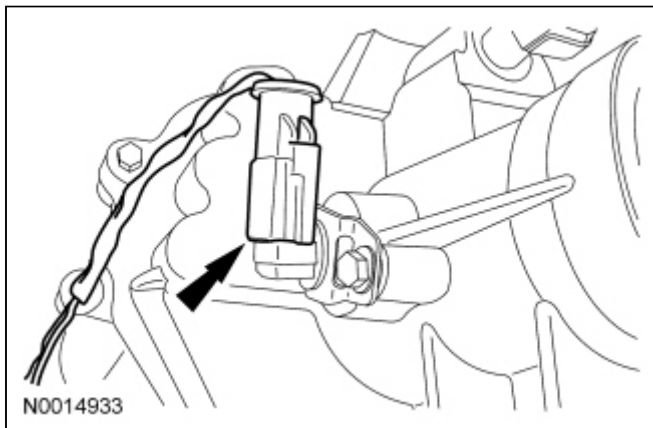

10. If transmission disassembly is necessary, remove the drain plug and drain the transmission fluid.
 - To install, tighten to 27 Nm (20 lb-ft).

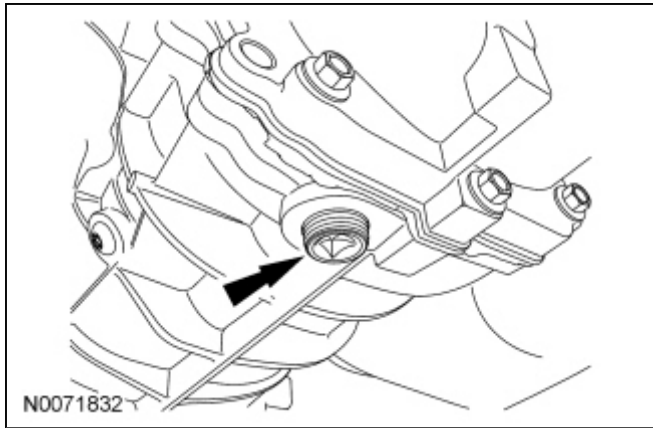

11. Position a transmission jack and support the transmission.

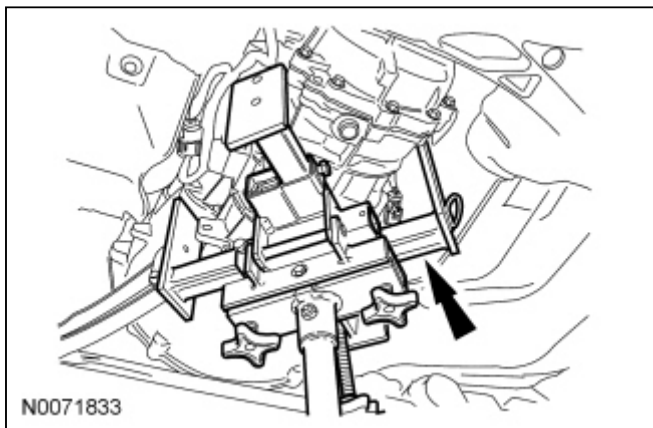

12. **NOTE:** Take note that the hump side of the crossmember goes up.

Remove the transmission crossmember. For additional information, refer to [Section 502-00](#).

13. Lower the transmission.
14. Remove the 2 rear gearshift lever nuts.

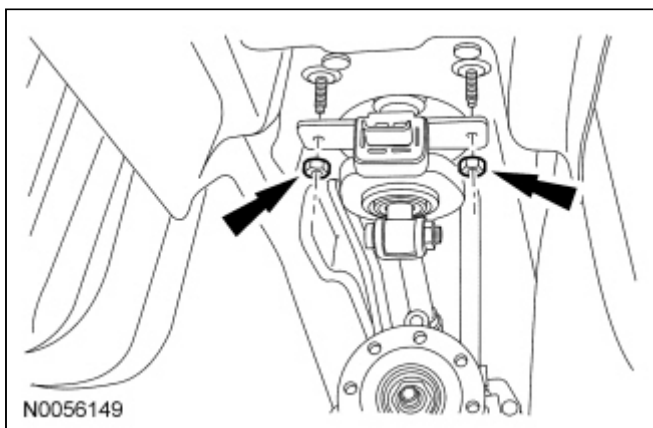

15. **NOTE:** Transmission removed for clarity.

Remove the gearshift lever assembly bolts and the gearshift assembly.

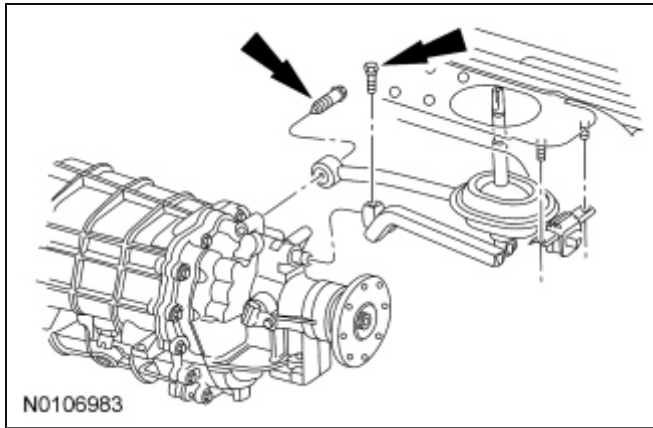

16. Detach the wire harness retaining clip from the transmission.

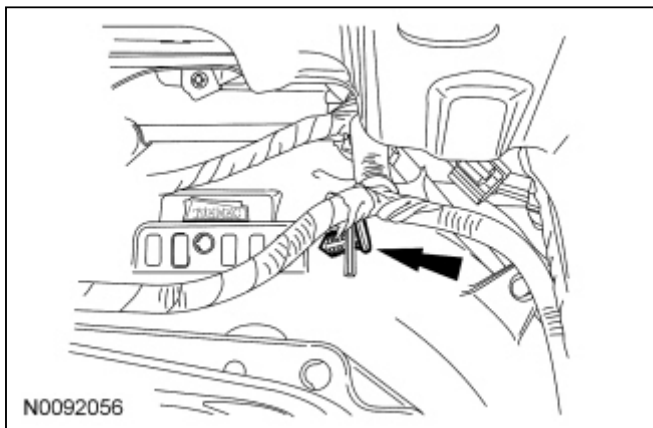

17. **NOTICE:** Do not spill brake fluid on painted or plastic surfaces or damage to the surface may occur. If brake fluid is spilled onto a painted or plastic surface, immediately wash the surface with water.

Release the clutch hydraulic tube clip and separate the connector from the clutch slave cylinder.

18. Remove the 2 spacer plate bolts.
19. Remove the 7 transmission-to-engine bolts.
20. Rotate the transmission 30 degrees counterclockwise. Securely strap the transmission to the transmission jack.

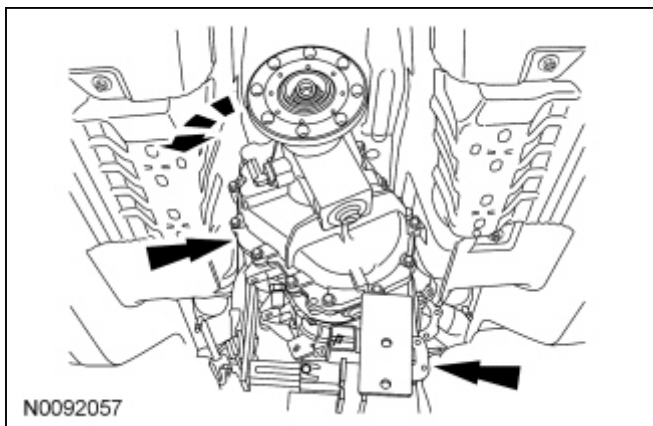

21. Pull the transmission rearward until the input shaft is clear of the pressure plate, then lower the transmission from the vehicle.

